

### FEATURE

- 1. Suitable Medium : Water, Sea Water, Non-causticity  
: liquid, Saturated Steam
- 2. Max.Working Pressure : 200 PSI
- 3. Max.Temperature : -10° to 100° C
- 4. Thread : BS 21

### FOOT VALVE

Fig. FV-1010

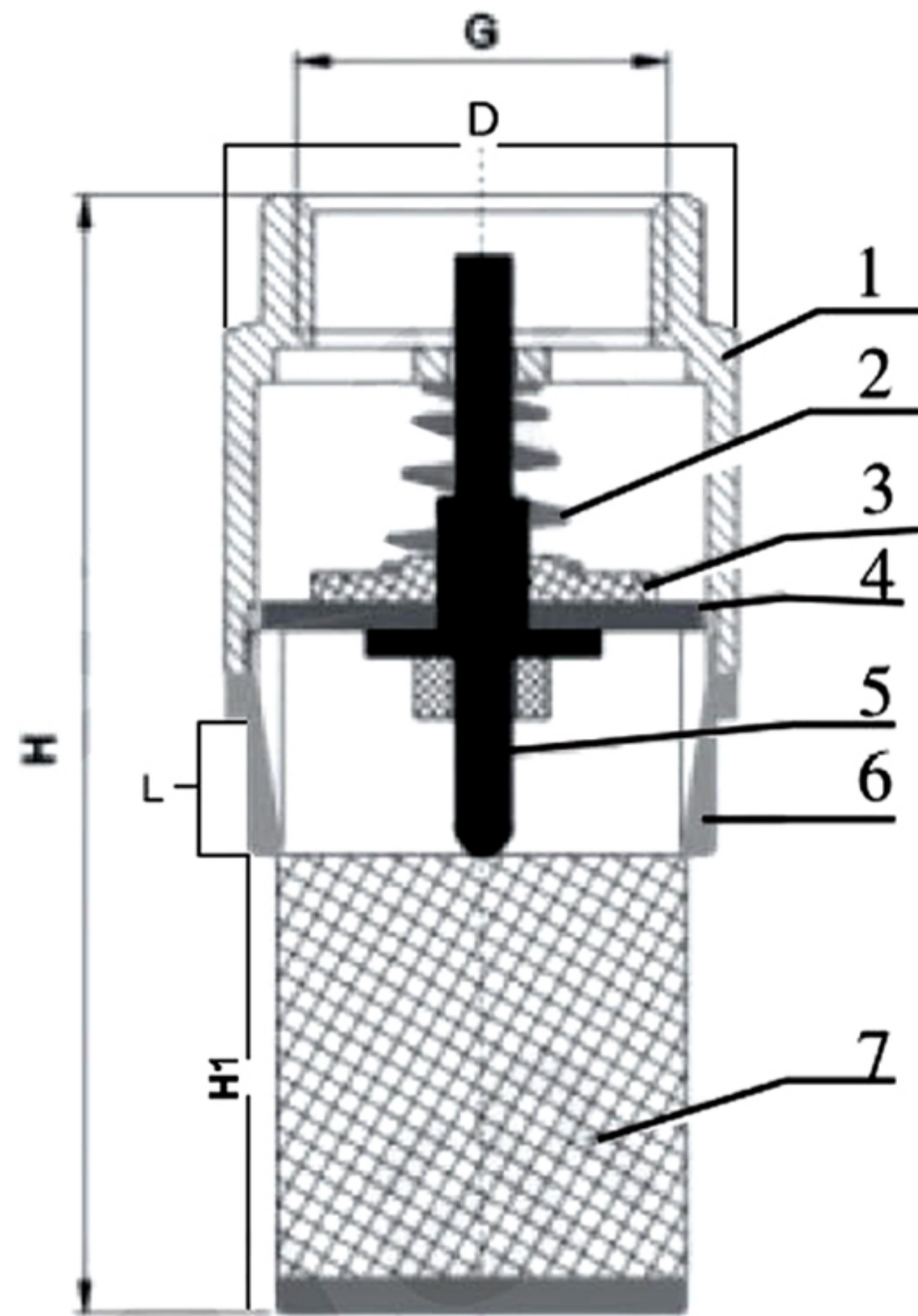

200 W.O.G



### MATERIALS

NO.	NAME OF PARTS	MATERIAL	ASTM SPECIFICATIONS
1	Body	Forged Brass	B283-C37700
2	Spring	SUS304	A167-304
3	Disc	Forged Brass	B283-C37700
4	Seal Gasket	EPDM	
5	Piston	Forged Brass	B283-C37700
6	Bonnet	Forged Brass	B283-C37700
7	Strainer	SUS304	A167-304

WORK PRESSURE		TEST	
		Shell (Water)	Seat (Air)
Saturated Steam	Cold Water, Oil, Gas		
Psi	125	200	80
Bar	10.3	13.8	5.5

### Note :

1. End threads conform to the British standard taper pipe threads.
2. Each valve is individually tested for seat and shell tightness.
3. Minimum and maximum working temperature - 10° to 100°C
4. These valve conform to the requirements of MSS SP-110

### DIMENSIONS

SIZE	G	D	L	H	H1	Weight / kgs
1/2"	15	33.5	11.5	74.5	30	0.15
3/4"	20	38.8	14.3	87.6	36	0.27
1"	25	45.4	13.7	102.3	46	0.28
1.1/4"	32	58.6	14.5	112	51	0.35
1.1/2"	40	61.6	16.3	126.3	58	0.56
2"	50	81.6	20.2	150.5	70	1.34
2.1/2"	65	98.4	25.3	177	76	2.9
3"	80	111.0	23.1	205	92	4.1
4"	100	144.5	29.0	223	120	4.25

Unit : mm.